

Technical Data Two Speed Motor – Two Windings

Motor type	Power (kW)	RPM	In 400 V (A)	Power factor Cos φ	Tn (Nm)	Ts/Tn	Is/In	AC brake In (mA)	DC brake In (mA)	Z ₀ (starts/hour)	Moment of inertia Jx 10 ⁻⁴ Kg·m ²	Max Brake torque (Nm)	A-Sound pressure dB(A)	Weight (Kg)
2 / 12 pole		S3 40%										3000 / 500 r.p.m.		
BADA 80 B2/12	0.45 0.07	2840 435	1.35 0.70	0.76 0.63	1.51 1.54	1.9 1.9	4.9 1.4	140	150	1700 24000	27.21	18	65 43	15.5
BADA 90 SB2/12	0.75 0.11	2800 400	2.10 1.05	0.82 0.61	2.56 2.63	3.0 2.0	5.2 1.4	300	150	1800 20000	26.15	38	72 44	22.5
BADA 90 LA2/12	1.10 0.15	2800 400	2.80 1.35	0.82 0.63	3.75 3.58	3.2 2.1	5.4 1.4	300	150	1800 20000	30.53	38	72 44	23
BADA 100 LB2/12	1.85 0.25	2850 410	4.1 2.2	0.87 0.52	6.20 5.82	3.0 2.2	6.3 1.5	300	150	1100 11000	60.07	50	73 47	36
BADA 112 MB2/12	3.00 0.45	2855 430	6.5 3.2	0.86 0.49	10.04 9.99	3.0 2.1	6.7 1.8	280	470	1200 10000	125.7	80	73 50	45
BADA 132 SB2/12	4.00 0.65	2880 450	8.9 4.8	0.85 0.56	13.26 13.79	3.0 1.8	7.0 1.6	580	680	350 2200	277.7	150	73 55	78
BADA 132 MA2/12	5.50 0.90	2870 450	11.5 6.7	0.88 0.56	18.30 19.10	3.0 1.8	7.5 1.6	580	680	350 2200	352.0	150	73 55	87
BADA 132 MB2/12	7.00 1.10	2880 450	15.7 8.5	0.85 0.56	23.21 23.34	3.0 1.8	7.5 1.6	580	680	350 2200	432.0	150	73 55	98
BADA 160 MB2/12	8.00 1.30	2890 470	15.9 9.5	0.92 0.42	26.44 26.41	3.0 2.0	8.0 2.1	1390	860	250 1200	683.0	190	74 58	154
BADA 160 LA2/12	11.00 1.80	2890 470	21.4 12.8	0.92 0.42	36.35 36.57	3.0 2.0	8.0 2.1	1390	860	250 1200	858.0	190	74 58	171
BADA 180 LB2/12	16.00 2.60	2910 470	30.6 12.2	0.93 0.46	52.51 52.83	3.0 1.8	8.0 2.0	950	1100	200 1000	1740.0	300	78 59	243

Hoisting motors 4/16 pole

Motor Type	Power (kW)	RPM	In 400 V (A)	AC brake In (mA)
Service duty S4 (40% 4 pole – 25% 16 pole)		1500 / 375 r.p.m.		
BAPKDA 132 MA4/16	2.8 / 0.7	1450 / 350	7.3 / 5.1	580
BAPKDA 132 MB4/16	4.0 / 1.1	1450 / 350	10.8 / 7.6	580
BAPKDA 160 MA4/16	5.5 / 1.3	1420 / 335	11.6 / 8.0	1390
BAPKDA 160 MB4/16	7.3 / 1.8	1420 / 330	16.2 / 11.4	1390
BAPKDA 160 LB4/16	10.0 / 2.5	1420 / 330	22.2 / 15.9	1390
BAPKDA 180 LA4/16	13.2 / 3.0	1450 / 350	25.0 / 21.7	950
BAPKDA 200 LB4/16	16.0 / 4.0	1450 / 350	31.5 / 27.4	950
BAPKDA 225 S4/16	19.0 / 4.8	1470 / 360	38.2 / 28.0	1350
BAPKDA 225 M4/16	24.0 / 6.0	1470 / 360	47.3 / 34.7	1350
BAPKDA 250 M4/16	30.0 / 7.5	1465 / 360	58.7 / 43.3	2000
BAPKDA 280 S4/16	40.0 / 10.0	1465 / 360	78.3 / 57.7	2000
BAPKDA 280 M4/16	50.0 / 12.5	1465 / 360	97.9 / 72.2	2000

1. Motor characteristic values reported in the tables refer to continuous duty (S1), 50 Hz frequency, ambient temperature max. 40 °C, altitude up to 1000 m. above sea level operating condition.

2. DC brake is provided on request only on BA series motors

at one metre range from the motor according to the Acurve (ISO 1680). The shown noise levels refer to motor no-load operating condition and should be regarded with a tolerance of ± 3dB.

4. Max brake torque and Z₀ values refer to AC brake. Go to

starts with load according to the formula expressed at page 22. The number of starts with load (Zload) is indicative and it has to be operatively tested for confirmation. The use of Thermo-protectors is strongly recommended when the operative number of starts is close to the calculated Zload.

M.G.M. motori elettrici S.p.A. is present in more than 40 countries around the world with sales/parts outlets and customer service. Please contact MGM customer assistance to find further information about MGM in the world. To clearly identify a spare part it's necessary to provide the item number (shown on the drawing below), the motor type, the rated voltage and frequency supply for electric parts such as the stator, the brake coil and the rectifier. For all spare parts belonging to BA 250-280 series, we pls you to contact us.

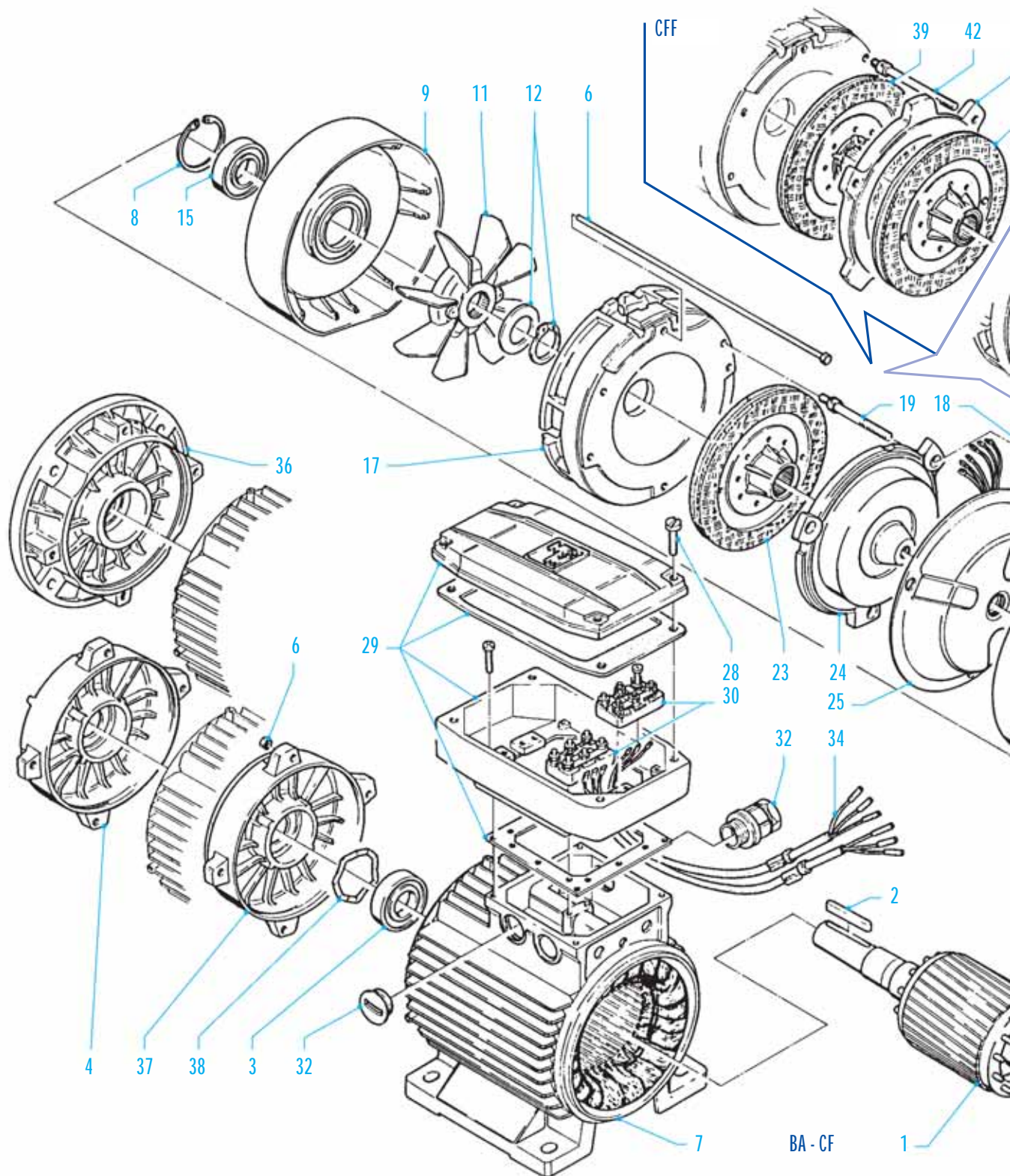

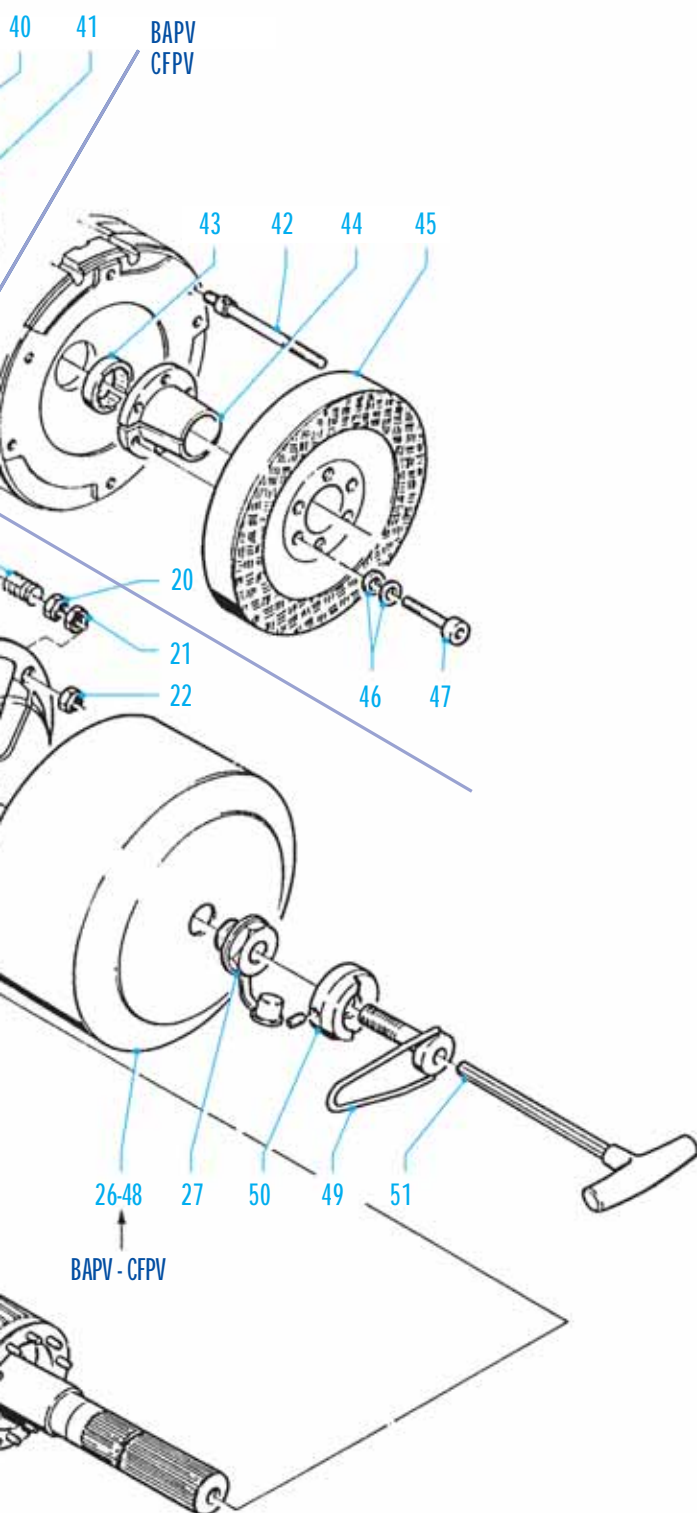

Complete rotor	1
Key	2
Bearing Drive End side	3
Endshield Drive End (front cover)	4
Tie rod assembly	6
Stator frame	7
Circlip	8
Endshield brake side (rear cover)	9
Fan	11
Fan fixing accessories	12
Bearing Non Drive Side	15
Brake Friction Surface	17
Spring	18
Brake adjuster	19
Brake torque adjuster locknut	20
Air gap adjusting nut	21
Brake coil locknut	22
Brake Disc	23
Brake Moving Element	24
Brake Coil	25
Brake Cover (BA-CF)	26
Hexagonal Rear Nut (socket head nut)	27
Terminal Box Screws	28
Terminal Box (single or double)	29
Terminal Board	30
Cable Gland	32
Brake Coil Connection Cables	34
Flange B5 (Flange Mounting)	36
Flange B14 (Face Mounting)	37
Elastic Washer	38
Brake Disc (BAF-CFF)	39
Additional Brake surface (BAF-CFF)	40
Additional Brake Disc (BAF-CFF)	41
Long Brake Adjuster (BAPV-BAF-CFF-CFPV)	42
Spacer (BAPV-CFPV)	43
Taper Bush (BAPV-CFPV)	44
Flywheel (BAPV-CFPV)	45
Elastic Washer (BAPV-CFPV)	46
Taper bush fixing screws (BAPV-CFPV)	47
Brake Cover (BAPV-BAF-CFPV-CFF)	48
Brake Release Screw	49
Fulcrum Hub for brake release (on request only)	50

brake linings wear

Brake linings wear is mainly affected by the environmental conditions in which the motor operates, by the frequency of starts, by the energy dissipated at each stop and by the torque provided by the brake. The lining temperature rises with the braking frequency and with the moment of inertia applied to the shaft. When the lining temperature rises, the lining wear increases and consequently the braking time is longer. BA series motors are designed to have continuous cooling of the braking surfaces so as to reduce brake disc wear to have a shorter braking time.

The life cycle of the brake linings can be roughly expressed by the number of brake interventions and can be approximately calculated as follows:

$$n = W_{tot} / W_b$$

where W_b (J) is the work done during each braking action and W_{tot} (J) is obtained from the table for each type of brake motor. However, it is necessary to check the brake disc wear periodically to replace the brake disc before it is completely worn. If you want to estimate the interval between two successive air gap adjustment in a specific application, note that the brake linings wear is greater than usual during the run-in (a few thousands stops).

On PV series brake motors W_{tot} shown in the table have to be multiplied by 0.5 and the moment of inertia have to be calculated considering the presence of the flywheel. The indicative number of AC brake stops N_{intAC} between two successive air gap adjustments on a BA motor is given by the following formula:

$$N_{intAC} = E_{rBA} / W_b$$

while the N_{intDC} for DC brake motors is given by : $N_{intDC} = N_{intAC} \cdot 0.65$

	71	80	90	100	112	132	160	180	200	225
W_{tot} (MJ)	537	705	952	1148	1438	2255	3290	4355	4355	5226
E_r (MJ)	56	80	95	105	130	200	290	385	385	462

For BA 250-280 pls contact MGM. The indicative number of DC brake stops N_{intBM} between two successive air gap adjustments on a BM motor is given by the following formula:

$$N_{intBM} = E_{rBM} / W_b$$

E_{rBM} values are shown at pag. 39 (BM section).

Starting and braking time

Starting current for an asynchronous motor is always much higher than the nominal current. When the starting time is excessively long, there are electromechanical disturbances and higher temperatures on winding, damaging the motor. For information on maximum starting time allowed for each type of motor, please contact MGM. An indicative value for starting time t_s (expressed in seconds) and the angle of rotation φ_s (expressed in radians) can be obtained as follows:

$$t_s = \frac{(J_{mot} + J_{app}) \cdot n}{9.55 (T - T_{load})} \quad \varphi_s = \frac{t_a \cdot n}{19.1}$$

Where J_{app} (Kgm^2) is the moment of inertia referred to the motor shaft, M_{load} (Nm) is the opposing torque to the motor, J_{mot} (Kgm^2) is the moment of inertia of the motor, n (RPM) is the rated motor RPM, T is the average starting torque, $T=(0,8 \div 0,9)T_s$ (see the technical data table for J_{mot} , n and T_s of the selected motor).

An indicative braking time t_r (s) can be calculated as follows: $t_r = \frac{J_{tot} \cdot n}{9.55 (T_b \pm T_{load})} + \frac{t_B}{1000}$

Brake electrical reaction time t_B (ms)

Motor Type	AC Brake	DC Brake (Standard)	DC Brake (Quick)
BA 71-80-90	7	80	20
BA 100-112	9	80	30
BA 132-160	12	85	30
BA 180-200	12	90	30
BA 225	14	100	35
BA 250	14	-	-
BA 280	14	-	-

Where: J_{tot} total moment of inertia at the motor shaft (Kgm^2)
 n motor RPM (min^{-1})
 T_b brake torque (Nm)
 T_{load} resisting load torque (Nm) with + sign if matches the brake torque, or - sign if opposite.
 t_B brake electrical reaction time (ms)

BA series 71 – 280 dimensions

Size	BA 71	BA 80	BA 90 S	BA 90 L	BA 100 L	BA 112 M	BA 132 S	BA 132 M	BA 160 M	BA 160 L	BA 180 L	BA 200 L	BA 225 S	BA 225 M	BA 250M	BA 280 S	BA 280 M
A	112	125	140	140	160	190	216	216	254	254	279	318	356	356	406	457	457
B	90	100	100	125	140	140	140	178	210	254	279	305	286	311	349	368	419
C	45	50	56	56	63	70	89	89	108	108	121	133	149	149	168	190	190
D*	14	19	24	24	28	28	38	38	42	42	48	55	60	60	65	65	75
d	M5	M6	M8	M8	M10	M10	M12	M12	M16	M16	M16	M16	M16	M16	M20	M20	M20
E*	30	40	50	50	60	60	80	80	110	110	110	110	140	140	140	140	140
Fa	9.5	11.5	11.5	11.5	14.5	14.5	14.5	14.5	18.5	18.5	18.5	18.5	18.5	18.5	18.5	18.5	18.5
Fb	M6	M6	M8	M8	M8	M8	M10	M10									
f	5	6	8	8	8	8	10	10	12	12	14	16	18	18	18	18	20
g	11	15.5	20	20	24	24	33	33	37	37	42.5	49	53	53	53	58	67.5
H	71	80	90	90	100	112	132	132	160	160	180	200	225	225	250	280	280
h	5	6	7	7	7	7	8	8	8	8	9	10	11	11	11	11	12
I	7	10	10	10	12	12	12	12	14.5	14.5	15	18.5	18	18	22	24	24
K	10.5	14	14	14	16	16	22	22	24	24	24	30	33	33	33	24	24
L	148	162	171	196	217	229											
L1	184	194	207	232	254	262	294	339	373	395	420	446	440	440	436	436	436
Ma	130	165	165	165	215	215	265	265	300	300	300	350	400	400	500	500	500
Mb	85	100	115	115	130	130	165	165									
Na	110	130	130	130	180	180	230	230	250	250	250	300	350	350	450	450	450
Nb	70	80	95	95	110	110	130	130									
Oa	3.5	3.5	3.5	3.5	4	4	4	4	5	5	5	5	5	5	5	5	5
Ob	2.5	3	3	3	3.5	3.5	3.5	3.5									
Pa	160	200	200	200	250	250	300	300	350	350	350	400	450	450	550	550	550
Pb	105	120	140	140	160	160	200	200									
Q	344	380	412	436	487	505	600	640	745	789	865	890	995	1000	1155	1155	1210
QBAF-BAPV	368	403	436	460	511	531	634	672	765	809	907	932	1014	1035			
R	80	80	98.5	98.5	98.5	98.5											
R1	135	135	170	170	170	170	199	199	268	268	268	268	327	327	327	327	327
S	10	12	12	12	14	14	15	15	15	15	15	15	20	20	18	18	18
V	8	9.5	10.5	10.5	12.5	13.5	16	16	21	21	24	24	32	32	32	40	40
W	105	113	127	127	138	158			165	165	188	188	224	224	252	252	252
W1	121	130	148	148	162	176	215	215	246	246	266	266	341	341	361	361	361
Y	145	160	180	180	196	218	265	265	324	324	357	357	430	430	493	493	493
Z	75	75	98.5	98.5	98.5	98.5											
Z1	86	86	112	112	112	112	151	151	167	167	167	167	202	202	202	202	202

* 225S-225M 2 pole D=55 E=110, 250M 2 pole D=160 E=140, 280S-280M 2 pole D=65 E=140

Notes:

QBAF is the Q dimension for BAF series

QBAPV is the Q dimension for BAPV series

Cable glands are M 20 on size 71 up to 80

M 25 on size 90 up to 112

M 32 on size 132